

TIGER-STONE

The road to the future!



Vanku BV
Peelbaan 7
5121DB RIJEN
The Netherlands
info@vanku.nl

TIGER-STONE

The road to the future!

The largest innovation in mechanical paving.

The Tiger-Stone is the solution for road paving. Not only for new stones but also for used stones the Tiger-stone is well suited. Because of its ergonomical design, paving is less intense for pavers. Pavers can work in the best circumstances and their joints will not suffer from the heavy work. And older workers can still fulfill their jobs as pavers.



The stones will slide out of the Tiger-stone. The Tiger-stone will drive away from the road and gravity will push the stones in the road with precision and pressure. This will result in a beautifully paved road. The road that will be layed can be paved in every desired pattern including the edge finishing.



The Tiger-stone is electrically powered and because of this it doesn't produce noises. Due the solid construction the Tiger-stone is not sensitive for maintenance. The Tiger-stone is amazingly easy to control because of the road tracking system. The road tracking system follows the curbstone automatically so steering is not required. Even in curves the Tiger-stone will steer automatically.



Road tracking system



TIGER-STONE

The road to the future!

Hoe does the Tiger-stone work?

Pavers can start using the Tiger-stone very fast with a quick-start SOP. The startup procedure is explained with a lot of pictures. With a remote controller the tiger-stone can be moved in position.



Pavers can stand in the Tiger-stone on a platform. They can pick the stones out of the hopper and place them on the slidingboard in the preferred pattern.



The side guides for the Tiger-stone can be adjusted to the width of the road. The sliding board can be mounted on the Tiger-Stone and the stones can be paved from the road in the the machine. The hopper in the Tiger-stone can be filled by a loader and then the Tiger-stone is ready to start paving.



By pushing a button the Tiger-stone will be driven; steering is not needed while this is controlled by the road tracking system.



TIGER-STONE

The road to the future!

Tigerstone 6000

Maximum road width:	600 cm
Capacity per day:	normal: 300 m ² ; up to: 500m ²
Power:	1,5 kW
Electrical connection:	16 A, 230V
Width:	2100 mm
Length:	6270 mm
Height:	1620 mm
Weigth:	2500 kg

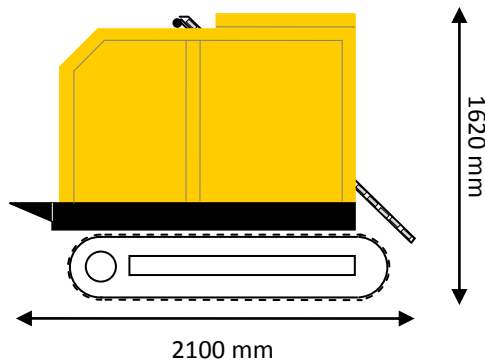
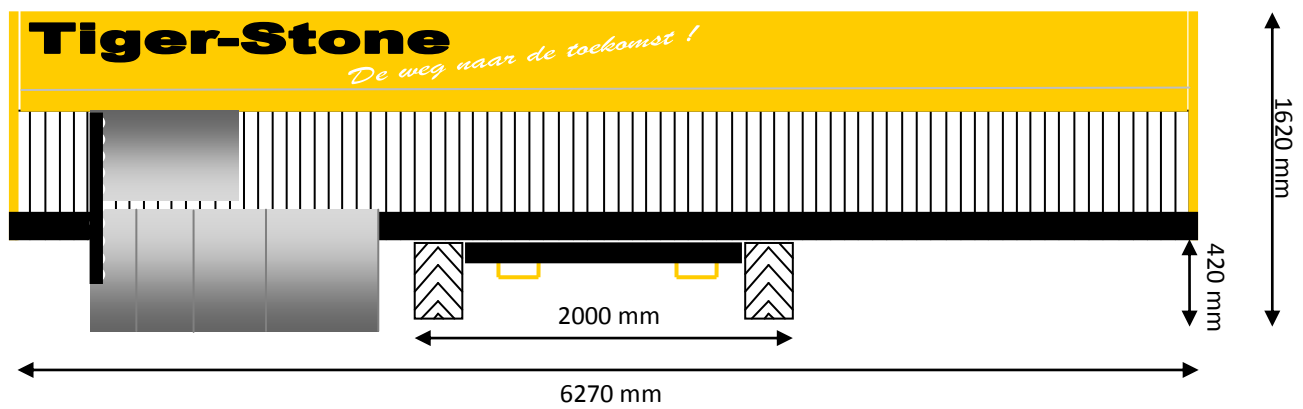

Nova-award winner!

The Nova award is a worldwide innovation award handed out by CIF (Construction Innovation Forum), an independent organisation who supports innovation in the Construction business. In 2011 the Tiger-stone was the proud winner of this award!



What can the Tiger-stone do for you?

- Better working conditions
- Motivated and enthusiastic staff
- A high daily production. 500 m² is possible
- High quality of the pavement. Including the edge finishing.
- No cutting is required
- Different stones and patterns can be paved at the same time.
- Disabled employees can be productive again
- Short payback time
- Easy to handle
- Low maintenance costs

These are just a few advantages for you or your company!

Contact

Vanku B.V.
Peelbaan 7
5121DB RIJEN
info@vanku.nl
www.vanku.nl
www.tiger-stone.nl

